

Operating and Service Manual
HP 85054D Type-N
Economy Calibration Kit

SERIAL NUMBERS

This manual applies directly to HP 85054D calibration kits with serial number prefix 3101A.

The calibration devices in this kit are individually serialized. Record the device serial numbers in the table provided in this manual (see “Device Serial Numbers” in Chapter 1).



HP Part No. 85054-90050
Printed in USA January 1997

Edition 2.1

Notice

The information contained in this document is subject to change without notice.

Hewlett-Packard makes no warranty of any kind with regard to this material, including, but not limited to, the implied warranties of merchantability and fitness for a particular purpose. Hewlett-Packard shall not be liable for errors contained herein or for incidental or consequential damages in connection with the furnishing, performance, or use of this material.

Restricted Rights Legend.

Use, duplication, or disclosure by the U.S. Government is subject to restrictions as set forth in subparagraph (c) (1) (ii) of the Rights in Technical Data and Computer Software clause at DFARS 252.227-7013 for DOD agencies, and subparagraphs (c) (1) and (c) (2) of the Commercial Computer Software Restricted Rights clause at FAR 52.227-19 for other agencies.

CERTIFICATION

Hewlett-Packard Company certifies that this product met its published specifications at the time of shipment from the factory. Hewlett-Packard further certifies that its calibration measurements are traceable to the United States National Institute of Standards and Technology (NIST, formerly NBS), to the extent allowed by the institute's calibration facility, and to the calibration facilities of other International Standards Organization members.

WARRANTY

This Hewlett-Packard instrument product is warranted against defects in material and workmanship for a period of one year from date of delivery. During the warranty period, Hewlett-Packard Company will, at its option, either repair or replace products which prove to be defective.

For warranty service or repair, this product must be returned to a service facility designated by HP. Buyer shall prepay shipping charges to HP and HP shall pay shipping charges to return the product to Buyer. However, Buyer shall pay all shipping charges, duties, and taxes for products returned to HP from another country.

HP warrants that its software and firmware designated by HP for use with an instrument will execute its programming instructions when properly installed on that instrument. HP does not warrant that the operation of the instrument, or software, or firmware will be uninterrupted or error free.

LIMITATION OF WARRANTY

The foregoing warranty shall not apply to defects resulting from improper maintenance by Buyer, Buyer-supplied software or interfacing, unauthorized modification or misuse, operation outside of the environmental specifications for the product, or improper site preparation or maintenance.

NO OTHER WARRANTY IS EXPRESSED OR IMPLIED. HP SPECIFICALLY DISCLAIMS THE IMPLIED WARRANTIES OR MERCHANTABILITY AND FITNESS FOR A PARTICULAR PURPOSE.

EXCLUSIVE REMEDIES

THE REMEDIES PROVIDED HEREIN ARE BUYER'S SOLE AND EXCLUSIVE REMEDIES. HP SHALL NOT BE LIABLE FOR ANY DIRECT, INDIRECT, SPECIAL, INCIDENTAL, OR CONSEQUENTIAL DAMAGES, WHETHER BASED ON CONTRACT, TORT, OR ANY OTHER LEGAL THEORY.

ASSISTANCE

Product maintenance agreements and other customer assistance agreements are available for Hewlett-Packard Products.

For any assistance, contact your nearest Hewlett-Packard Sales and Service Office. Addresses are provided at the back of this manual.

Contents

1. General Information	
Calibration Kit Overview	1-1
Equipment Required but Not Supplied	1-2
Serial Numbers	1-2
Calibration Kits Documented in this Manual	1-2
Calibration Kit History	1-3
HP 85054D Kits with Serial Prefix 2901A	1-3
Device Serial Numbers	1-3
Incoming Inspection	1-4
Precision Slotless Connectors	1-4
Precision slotless connectors have the following characteristics:	1-5
Clarifying Connector Sex	1-5
Preventive Maintenance	1-5
2. Specifications	
Environmental Requirements	2-1
Temperature – What To Watch Out For	2-1
Mechanical Characteristics	2-2
Center Conductor Protrusion and Pin Depth	2-2
Electrical Specifications	2-3
Residual Errors after Calibration	2-3
3. User Information	
The Calibration Devices and Their Use	3-1
Broadband Loads	3-1
Offset Opens and Shorts	3-1
Adapters	3-1
HP 8510 Information	3-2
Loading Calibration Constants	3-2
For HP 8510A/B	3-2
For HP 8510C	3-2
Duplicating a Calibration Constants Disk	3-3
Performing a Calibration	3-3
Examining Calibration Constants	3-4
Changing Calibration Constants	3-5
HP 8720 Series Information	3-6

4. Gaging and Making Connections	
Electrostatic Discharge	4-1
Visual Inspection	4-1
Obvious Defects or Damage	4-1
Mating Plane Surfaces	4-2
Precision Slotless Connectors	4-2
Connector Wear	4-2
Cleaning Connectors	4-2
Pin Depth	4-3
Definition of Pin Depth	4-3
Importance of Pin Depth	4-3
Gaging Connectors	4-4
Gage Intent	4-4
Gage Accuracy	4-4
When to Gage Connectors	4-6
Reading the Connector Gage	4-6
Adjusting the Connector Gage	4-8
Measuring the Connector	4-10
Male Type–N Connectors	4-10
Female Type–N Connectors	4-12
Connections	4-14
Connection Procedure	4-14
Using the Torque Wrench	4-15
Disconnection Procedure	4-17
Handling and Storage	4-17
5. Performance Verification	
What Recertification Provides	5-1
How Often to Recertify	5-2
Where to Send a Kit for Recertification	5-2
How Hewlett–Packard Verifies the Devices in this Kit	5-2
6. Troubleshooting	
Returning a Kit or Device to HP	6-1
More Information	6-1
7. Replaceable Parts	
A. Standard Definitions	
Electrical Characteristics	A-1
Standard Class Assignments	A-1
Nominal Standard Definitions	A-1
Setting System Impedance	A-1
Version Changes	A-1

Index

Figures

1-1. Typical Kit Serial Number Label	1-2
4-1. Connector Pin Depth	4-4
4-2. Reading the Connector Gage	4-7
4-3. Adjusting the Connector Gage	4-9
4-4. Gaging a Type-N Male Connector	4-11
4-5. Gaging a Type-N Female Connector	4-13
4-6. Correct Wrench Position	4-15
4-7. Incorrect Wrench Position	4-15
4-8. Using the Torque Wrench	4-16
6-1. Troubleshooting Flowchart	6-2
7-1. Replaceable Parts	7-3

Tables

1-1. Kit and Device Serial Number Record	1-3
2-1. Environmental Requirements	2-1
2-2. Electrical Specifications	2-3
4-1. Pin Depth Limits	4-5
4-2. Torque Wrench Information	4-15
7-1. Replaceable Parts	7-2
A-1. Standard Class Assignments for the HP 8510	A-2
A-2. Standard Class Assignments for the HP 8720 Series	A-3
A-3. Standard Class Assignments Blank Form	A-4
A-4. Standard Definitions HP 8510 with Type-N	A-5
A-5. Standard Definitions HP 8720 Series with Type-N	A-6
A-6. Standard Definitions Blank Form	A-7

General Information

Calibration Kit Overview

The HP 85054D type-N economy calibration kit is used to calibrate network analyzer systems (such as the HP 8510 or HP 8720 series) for measurements of components with type-N connectors up to 18 GHz.

The calibration kit consists of the following:

- Offset opens and shorts, and broadband load terminations.
- Four type-N to 7 mm adapters.
- Two type-N to type-N adapters.
- A 3/4 inch, 135 N-cm (12 in-lb) torque wrench for use on the type-N connectors.
- A spanner wrench.
- A data disk that contains the calibration constants of the devices in the kit for HP 8510 systems.

The standards in this calibration kit allow you to perform simple 1- or 2-port and TRM (thru-reflect-match) calibrations.

This manual describes the HP 85054D calibration kit and provides replacement part numbers, specifications, and procedures for using, maintaining and troubleshooting the kit.

Option 002 adds the following:

- A data tape that contains the calibration constants of the devices in the kit for HP 8510A/B systems.

Option 1BP

Adds a MIL-STD 45662A Certificate of Calibration and the corresponding calibration data to the instrument. This option must be ordered when the instrument order is placed.

Option 1BN

Adds a MIL-STD 45662A Certificate of Calibration to the instrument. This option must be ordered when the instrument order is placed.

Note

This manual assumes you know proper connector care. If not, refer to “Principles of Microwave Connector Care—Quick Reference Card”, located in the back of this manual. Refer to Chapter 7, “Replaceable Parts” for the HP part number, if another copy is needed.

Or, contact your nearest HP Sales office for the customer training course: “Understanding Connectors Used With Network Analyzers”.

- HP 85050A + 24A (on site)
 - HP 85050A + 24D (at HP sales office)
-

Equipment Required but Not Supplied

Connector gage sets, open-end wrenches and various connector cleaning supplies are *not* provided in this kit. These or similar items are recommended to ensure the successful operation of this calibration kit. (Refer to Chapter 7, “Replaceable Parts”, for ordering information.)

Serial Numbers

A serial number label is attached to this calibration kit. A typical kit serial number label is shown in Figure 1-1. The first four digits followed by a letter comprise the serial number prefix; the last five digits are the suffix, unique to each calibration kit.

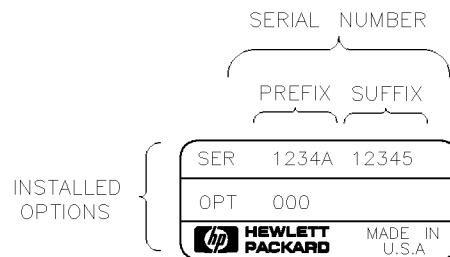

Figure 1-1. Typical Kit Serial Number Label

Calibration Kits Documented in this Manual

This manual applies to any HP 85054D calibration kit whose serial prefix is listed on the title page. If your calibration kit has a different serial number prefix than the one listed on the title page, refer to the “Calibration Kit History” section below for information on how this manual applies.

Calibration Kit History

This section describes calibration kits with serial number prefixes lower than the ones listed on the title page.

HP 85054D Kits with Serial Prefix 2901A

These calibration kits did not have the calibration constants disk to support the HP 8510C network analyzer. The part numbers provided in this manual are the recommended replacement parts for these kits. The devices in these kits should meet the specifications published in this manual.

Device Serial Numbers

In addition to the kit serial number, the devices in this kit are individually serialized (serial numbers are either labeled on or scribed onto the body of each device). Record these serial numbers in Table 1-1. This can help you avoid confusing the devices in this kit with similar devices from other kits. Kit integrity is an important part of compliance with U.S. MIL-STD 45662A, should you need to comply with this standard. The adapters are for measurement convenience only and are not regarded as devices requiring a traceable path in order to comply with MIL-STD 45662A.

Table 1-1. Kit and Device Serial Number Record

Device	Serial Number
Calibration Kit	_____
Broadband Load (m)	_____
Broadband Load (f)	_____
Open (m)	_____
Open (f)	_____
Short (m)	_____
Short (f)	_____
Adapters	
Type-N (f) to Type-N (f)	_____
Type-N (m) to Type-N (m)	_____
Type-N (m) to 7 mm)	_____
Type-N (m) to 7 mm)	_____
Type-N (f) to 7 mm)	_____
Type-N (f) to 7 mm)	_____

Incoming Inspection

Refer to Figure 7-1 to verify a complete shipment. Use Table 1-1 to record the serial numbers of all serialized devices in your kit. To verify the electrical performance of the devices in this kit, see Chapter 5, “Performance Verification.”

The foam-lined storage case provides protection during shipping. If the case or any device appears damaged, contact the nearest Hewlett-Packard sales and service office. Hewlett-Packard will arrange for repair or replacement of incomplete or damaged shipments without waiting for a settlement from the transportation company. When you send the kit or device to Hewlett-Packard, include a service tag (found at the end of this manual) on which you provide the following information:

- Your company name and address.
- A technical contact person within your company, and the person's complete phone number.
- If you are returning a complete kit, include the model number and serial number.
- If you are returning one or more devices, include the part numbers and serial numbers.
- Indicate the type of service required.
- Include any applicable information. If a repair is needed, please describe the problem.

Precision Slotless Connectors

The female type-N connectors in this calibration kit are metrology-grade, precision slotless connectors (PSC). A characteristic of metrology-grade connectors is direct traceability to national measurement standards through their well-defined mechanical dimensions.

Conventional female center conductors are slotted. When mated, the female center conductor is flared by the male pin. Because physical dimensions determine connector impedance, electrical characteristics of the female connector (and connection pair) are dependent upon the mechanical dimensions of the male pin. While connectors are used in pairs, their male and female halves are always specified separately as part of a standard, instrument, or device under test. Because of these facts, making precision measurements with the conventional slotted connector is very difficult, and establishing a direct traceability path to primary dimensional standards is nearly impossible.

The precision slotless connector was developed to eliminate these problems. All PSCs are female. A PSC incorporates a center conductor with a solid cylindrical shell that defines the outside diameter of the female center pin. Its outside diameter and, therefore, the impedance in its region does not change. The inner part provides an internal contact that flexes to accept the allowed range of male pin diameters.

The calibration of a network analyzer having a conventional slotted female connector on the test port remains valid only when the device under test and all calibration standards have identical male pin diameters. For this reason PSC test port adapters are supplied in most Hewlett-Packard calibration kits.

Precision slotless connectors have the following characteristics:

- There is no loss of traceable calibration on test ports when the male pin diameter of the connector on the device under test is different from the male pin diameter of the calibration standard.
- The female PSC and its mating male connector can be measured and specified separately as part of the device either is attached to.
- All female connectors can have a known, stable impedance based only on the diameters of their inner and outer conductors.
- Female calibration standards can be fully specified. Their specifications and traceability are unaffected by the diameter of the male mating pin.
- A fully traceable performance verification is made using a precision 50Ω airline having a PSC.
- Measurement repeatability is enhanced due to non-changing connector characteristics with various pin diameters.

With PSCs on test ports and standards, the percentage of accuracy achieved when measuring at 50 dB return loss levels is comparable to using conventional slotted connectors measuring devices having only 30 dB return loss. This represents an accuracy improvement of about 10 times.

Clarifying Connector Sex

In this manual, devices are referred to in terms of their connector unless otherwise stated. For example, a male open has a male connector.

CAUTION During a measurement calibration, however, the HP 8510 and HP 8720 softkey menus will label a type-N calibration device with the sex of the analyzer's test port connector – *not* the device connector. For example, the label **SHORT (F)** on the display refers to the short that will be connected to the *female* test port.

Preventive Maintenance

The best techniques for maintaining the integrity of the devices in this kit include routine visual inspection and cleaning, and proper gaging and connection techniques. Failure to detect and remove dirt or metallic particles on a mating plane surface can degrade repeatability and accuracy and can damage any connector mated to it. Improper connections resulting from pin depth values being out of the *observed* limits (see Table 4-1) or from poor connection techniques can also damage these devices.

Visual inspection, cleaning techniques, proper gaging for pin depth, and connection techniques are all described in Chapter 4, “Gaging and Making Connections.”

Specifications

Environmental Requirements

Table 2-1. Environmental Requirements

Parameter	Required Values/Ranges
Operating Temperature ¹	20° to 26°C (68° to 79°F)
Error-Corrected Temperature Range ²	±1°C of measurement calibration temperature
Storage Temperature	-40° to +75°C (-40° to +167°F)
Altitude	
Operation	< 4,500 meters (≈15,000 feet)
Storage	< 15,000 meters (≈50,000 feet)
Relative Humidity	Always Non-Condensing
Operation	0 to 80% (26°C maximum dry bulb)
Storage	0 to 90%

¹ The temperature range over which the calibration standards maintain performance to their specifications.

² The allowable network analyzer ambient temperature drift during measurement calibration and during measurements when the network analyzer correction is turned on. Also, the range over which the network analyzer maintains its specified performance while correction is turned on.

Temperature - What To Watch Out For

Due to the small dimensions of the calibration devices, electrical characteristics will change with temperature. Therefore, the operating temperature is a critical factor in their performance. During a measurement calibration, the temperature of the calibration devices must be stable and within the range shown in Table 2-1.

Remember Your fingers are a heat source, so avoid handling the devices unnecessarily during calibration.

Performance verification and measurements of devices under test need not be performed within the operating temperature range of the calibration devices, but they must be within the error-corrected temperature of the network analyzer ($\pm 1^\circ\text{C}$ of the measurement calibration temperature). For example, if the calibration is performed at $+20^\circ\text{C}$, the error-corrected temperature range is $+19^\circ$ to $+21^\circ\text{C}$. It is then appropriate to perform measurements and performance verifications at $+19^\circ$, which is outside the operating temperature range of the calibration devices, since only the actual calibration must be performed within the operating temperature range.

Mechanical Characteristics

Center Conductor Protrusion and Pin Depth

Mechanical characteristics such as center conductor protrusion and pin depth are *not* performance specifications. They are, however, important supplemental characteristics related to electrical performance. Hewlett-Packard verifies the mechanical characteristics of the devices in this kit with special gaging processes and electrical testing. This ensures that the device connectors do not exhibit any center conductor protrusion and have proper pin depth when the kit leaves the factory.

Chapter 4, “Gaging and Making Connections”, explains how to use the gages provided in this kit to determine if the kit devices have maintained their mechanical integrity. (Refer to Table 4-1 for *typical* and *observed* pin depth limits.)

Electrical Specifications

Table 2-2. Electrical Specifications

Device	Frequency (GHz)	Parameter	Specification
Broadband Loads	DC to ≤ 2	Return Loss	≥ 40 dB ($\leq 0.01000 \rho$)
	> 2 to ≤ 8	Return Loss	≥ 36 dB ($\leq 0.01585 \rho$)
	> 8 to ≤ 18	Return Loss	≥ 34 dB ($\leq 0.01995 \rho$)
Adapters (both types)	DC to ≤ 8	Return Loss	≥ 34 dB ($\leq 0.0200 \rho$)
	> 8 to ≤ 18	Return Loss	≥ 28 dB ($\leq 0.0398 \rho$)
Offset Opens ¹	at 18	Deviation from Nominal: Phase	$\pm 1.5^\circ$
Offset Shorts ¹	at 18	Deviation from Nominal: Phase	$\pm 1.0^\circ$

¹ The specifications for the open and short are given as allowed deviation from the *nominal* model as defined in the standard definitions (see Table A-4 and Table A-5).

Residual Errors after Calibration

The HP 8510 “Specifications and Performance Verification” software can be used to obtain a printout of the residual errors after a calibration has been performed. Refer to the “Specifications and Performance Verification” section of the HP 8510C *On-Site Service Manual* for information on how to use the software.

User Information

The Calibration Devices and Their Use

The HP 85054D type-N economy calibration kit contains three types of type-N calibration devices with both male and female connectors: offset short circuits, offset open circuits, and 50 ohm broadband loads.

For measurement convenience, the kit also contains two type-N to type-N adapters and four type-N to 7 mm adapters. The adapters are primarily intended for use in measuring non-insertable devices, but can also be used as connector savers.

The following briefly describes the design and construction of all the calibration kit devices.

Broadband Loads

The broadband loads are metrology-grade, 50 ohm terminations which have been optimized for lowband performance up to 18 GHz. The rugged internal structure provides highly repeatable connections. A distributed resistive element on sapphire provides excellent stability and return loss.

Offset Opens and Shorts

The offset opens and shorts are built from parts that are precision machined. The offset short's inner conductors have a one-piece construction, common with the shorting plane. This construction provides for extremely repeatable connections. The offset opens have inner conductors which are supported by a strong, low-dielectric-constant plastic to minimize compensation values. Both the opens and shorts are constructed so that the pin depth can be controlled very tightly, thereby minimizing phase errors. The lengths of the offsets in the opens and shorts are designed so that the difference in phase of their reflection coefficients is approximately 180 degrees at all frequencies.

Adapters

Like the other devices in the kit, the adapters are built to very tight tolerances to provide good broadband performance, and to ensure stable, repeatable connections. The adapters are designed so that their nominal electrical lengths are the same, which allows them to be used in calibration procedures for non-insertable devices (such as adapter removal).

HP 8510 Information

Loading Calibration Constants

Use one of the following procedures to load the calibration constants into HP 8510 memory.

For HP 8510A/B

1. Insert the calibration constants (option 002) tape into the HP 85101 drive.
2. Press **TAPE/DISC**.
3. Select **LOAD**.
The analyzer displays **SELECT DATA TYPE TO LOAD**.
4. Select **CAL KIT 1-2**.
5. Select either *** 1** or *** 2**.
The analyzer displays **SELECT CAL KIT FILE TO LOAD**.
6. Select *** FILE 1** to load the calibration constants into memory.
7. Remove the tape from the drive.

For HP 8510C

1. Insert the calibration constants disk into the HP 85101 drive.
2. Press **DISC**.
3. Select **LOAD**.
The analyzer displays **SELECT DATA TYPE TO LOAD**.
4. Select **CAL KIT 1-2**.
5. Select either *** 1** or *** 2**.
The analyzer displays **USE KNOB OR STEP KEYS TO SELECT A FILE**.
6. Select **CK_NTYPD2** from the display menu.
7. Select **LOAD FILE**.
8. Remove the disk from the drive.

Duplicating a Calibration Constants Disk

Use the following procedure to make a backup copy of a calibration constants disk on an HP 8510C network analyzer. If you are using a different network analyzer, or are using an external disk drive, refer to the analyzer documentation.

1. Load the original calibration constants disk (see previous procedure).
2. Initialize a blank disk:
 - a. Insert the disk into the HP 85101 disk drive.
 - b. Press **DISC**.
 - c. Select **STORAGE IS INTERNAL SETUP DISC INITIALIZE DISC YES**.
3. With an initialized disk in the HP 85101 disk drive, transfer the calibration constants:
 - a. Press **DISC STORE**.
 - b. Select **CAL KIT/1-2 CAL KIT/*1**.
 - c. Select the appropriate data type.
4. Remove, write protect, and label the disk.

Performing a Calibration

Use the following steps to set up an HP 8510 network analyzer for a type-N calibration.

1. Be sure that the system impedance is set to 50 ohms by pressing **CAL MORE SET Z0**.
2. If the display does *not* read 50.0 Ω , press **5 0 X1**.
3. Load the type-N file from the calibration constants disk or tape. Refer to the “Loading Calibration Constants” section of this chapter.
4. Press **CAL TYPE N D.2**. The calibration options are available as softkeys on the display. As selections are made, more softkeys appear.
5. Follow the prompts on the display or refer to the HP 8510 *Operating Manual* for more information.

Note

During the calibration, you may be asked to choose **OPEN (M)**, **OPEN (F)**, **SHORT (M)**, or **SHORT (F)**. The (M) and (F) refer to the sex of the test port connector to which you are connecting the device. It does not refer to the sex of the calibration device. This convention is used in the softkey menus of the HP 8510 network analyzer during the calibration process. It is also used in the standard definitions, Table A-4.

Examining Calibration Constants

Use the following procedure to examine the calibration constants of a short. To examine the calibration constants of a different standard, substitute the standard number in step 3 with the standard number of the device you want to examine. For example, to examine the calibration constants for an open, press **2** **x1**. See Table A-4 and Table A-5, at the end of this manual, for the standard numbers.

1. Press **CAL**.
2. Select:
 - a. **MORE**.
 - b. **MODIFY 1** or **MODIFY 2** (depending on where the calibration constants are loaded).
 - c. **DEFINE STANDARD**.
3. Press **1** **x1** (the calibration standard number).
The softkey **SHORT** is underlined.
4. Select:
 - a. **SHORT L0 L1 L2 L3** (the analyzer displays the value of each L-term as the softkeys are selected).
 - b. **SPECIFY OFFSET**
 - c. **OFFSET DELAY** (the analyzer displays the value)
 - d. **OFFSET LOSS** (the analyzer displays the value)
 - e. **OFFSET Z0** (the analyzer displays the value)
 - f. **MINIMUM FREQUENCY** (the analyzer displays the minimum frequency).
 - g. **MAXIMUM FREQUENCY** (the analyzer displays the maximum frequency).
The softkey **COAX** is underlined
5. Select **PRIOR MENU** **LABEL STD**.
SHORT (M) is displayed on the analyzer (in the upper left corner of the display).
6. Press:
 - a. **PRIOR MENU** three times.
The top softkey is **DEFINE STANDARD**.
 - b. **ENTRY OFF**.

Changing Calibration Constants

Use the following procedure to change the calibration constants of a short. To change the calibration constants of a different standard, substitute the standard number in step 3 with the standard number of the device you want to change. For example, to change the calibration constants for an open, press **2** **x1**. See Table A-4 and Table A-5 at the end of this manual for the standard numbers.

Note Hewlett-Packard provides this procedure for users who wish to customize standards definitions for their own special purposes. Customers who do this need to be aware that doing so may invalidate the published specifications of their network analyzer.

For more information on how to modify calibration kit definitions, see product note 8510-5A (for ordering information see Chapter 7 “Replaceable Parts”).

1. Press **CAL**.
2. Select:
 - a. **MORE**.
 - b. **MODIFY 1** or **MODIFY 2** (depending on where the calibration constants are loaded).
 - c. **DEFINE STANDARD**.
3. Press **1** **x1** (the calibration standard number).
The softkey **SHORT** is underlined.
4. Select:
 - a. **SHORT L0**, and enter the new L-term value. Do the same for **L1**, **L2** and **L3**.
 - b. **SPECIFY OFFSET**.
 - c. **OFFSET DELAY**, and enter the new offset delay.
 - d. **OFFSET LOSS**, and enter the new offset loss.
 - e. **OFFSET Z0**, and enter the new Z_0 .
 - f. **MINIMUM FREQUENCY**, and enter the new minimum frequency.
 - g. **MAXIMUM FREQUENCY**, and enter the new maximum frequency.
The softkey **COAX** is underlined.
5. Select **PRIOR MENU** **LABEL STD**.
SHORT (M) is displayed on the analyzer (in the upper left corner of the display).
6. Select **TITLE DONE** **STD DONE (DEFINED)**.

7. Relabel the kit:

- a. Select **LABEL KIT** and follow the instructions on the analyzer. You can enter a total of 10 characters.
- b. Select **TITLE DONE**.

HP 8720 Series Information

The calibration constants for this kit have already been stored in the memory of the HP 8720 series network analyzers (includes HP 8719 and HP 8722). It is not necessary to reload these constants.

To select the type-N calibration constants, press **CAL** **Cal Kit** **Select Cal Kit**. A menu will appear showing all of the different connector types in which the analyzer can calibrate. Select **N 50Ω** for use with this kit.

Refer to the appropriate HP 8720 series *Operating Manual* for step-by-step calibration procedures and system uncertainty information.

Note During the calibration, you may be asked to choose **OPEN (M)**, **OPEN (F)**, **SHORT (M)**, or **SHORT (F)**. The (M) and (F) refer to the sex of the test port connector to which you are connecting the device. It does not refer to the sex of the calibration device. This convention is used in the softkey menus of HP 8720 series network analyzers during the calibration process. It is also used in the standard definitions, Table A-5.

Gaging and Making Connections

Electrostatic Discharge

Protection against ESD (electrostatic discharge) is essential while cleaning, inspecting, or connecting connectors attached to a static-sensitive circuit (such as those found in test sets).

Static electricity can build up on your body and can easily damage sensitive internal circuit elements when discharged by making contact with the center conductor. Static discharges too small to be felt can nevertheless cause permanent damage. Devices such as calibration components and devices under test can also carry an electrostatic charge.

- Always have a grounded antistatic mat in front of your test equipment and wear a grounded wrist strap having a 1 M Ω resistor in series with it.
- Ground yourself before you clean, inspect, or make a connection to a static-sensitive device or test port. You can, for example, grasp the grounded outer shell of the test port briefly to discharge static from your body.

Refer to Chapter 7, “Replaceable Parts”, for information on ordering supplies for ESD protection.

Visual Inspection

Visual inspection and, if necessary, cleaning should be done every time a connection is made. Metal particles from the connector threads may fall into the connector when it is disconnected. One connection made with a dirty or damaged connector can damage both connectors beyond repair.

In some cases, magnification is necessary to see damage on a connector. This is especially true with female connectors. The contact fingers on slotted connectors and on the inner contact of slotless connectors may become bent or broken. The use of a microscope with a magnification $\geq 10\times$ is recommended to detect this type of damage. Not all defects that are visible only under magnification will affect the electrical performance of the connector. Use the following guidelines when evaluating the integrity of a connector.

Obvious Defects or Damage

Examine the connectors first for obvious defects or damage: badly worn plating, deformed threads or bent, broken, or misaligned center conductors. Connector nuts should move smoothly and be free of burrs, loose metal particles, and rough spots.

Any connector that has obvious defects should be discarded or sent for repair.

Mating Plane Surfaces

Flat contact between the connectors at all points on their mating plane surfaces is required for a good connection. Look especially for deep scratches or dents, and for dirt and metal particles on the connector mating plane surfaces.

Also look for bent or rounded edges on the mating plane surfaces of the center and outer conductors and for signs of damage due to excessive or uneven wear or misalignment.

Light burnishing of the mating plane surfaces is normal, and is evident as light scratches or shallow circular marks distributed more or less uniformly over the mating plane surface. Other small defects and cosmetic imperfections are also normal. None of these affect electrical or mechanical performance.

If a connector shows deep scratches or dents, particles clinging to the mating plane surfaces, or uneven wear, clean and inspect it again. Damaged connectors should be discarded or sent for repair. Try to determine the cause of damage before connecting a new, undamaged connector in the same configuration.

Precision Slotless Connectors

Precision slotless female connectors are used to improve accuracy. The slotless contacts are not affected by the slight variations in male contact pin diameter, however, it is still advisable to inspect them regularly for damage.

Connector Wear

Connector wear eventually degrades performance. The more use a connector gets, the faster it wears and degrades. The wear is greatly accelerated when connectors are not kept clean. Calibration devices should have a long life if their use is on the order of a few times per week. The test port connectors on the network analyzer test set may have many connections each day, and are therefore more subject to wear. It is recommended that an adapter be used as a test port saver to minimize the wear on the test set's test port connectors. Replace all worn connectors.

Cleaning Connectors

For details on cleaning connectors, see “Principles of Microwave Connector Care—Quick Reference Card”, located in the back of this manual. Refer to Chapter 7, “Replaceable Parts”, for the HP part number if another copy is needed.

Pin Depth

Definition of Pin Depth

Pin depth is the distance the center conductor mating plane differs from being flush with the outer conductor mating plane (see Figure 4-1). Some coaxial connectors (such as 2.4 mm and 3.5 mm) are designed to have these planes nearly flush. Type-N connectors, however, are designed with a pin depth offset of approximately 5.26 mm (0.207 inch) not permitting these planes to be flush. The male center conductors are recessed by the offset value while the female center conductors compensate by protruding the same amount. This offset necessitates the redefining of pin depth with regard to protrusion and recession.

Protrusion will refer to a male type-N connector center conductor having a pin depth dimension of less than 5.26 mm (0.207 inch), or a female type-N connector center conductor having a dimension greater than 5.26 mm (0.207 inch).

Recession will refer to a male type-N connector center conductor having a pin depth dimension of greater than 5.26 mm (0.207 inch), or a female type-N connector center conductor having a dimension less than 5.26 mm (0.207 inch).

Note The gages intended for measuring the type-N connectors compensate for the designed offset of 5.26 mm (0.207 inch), therefore, protrusion and recession readings will be in relation to a *zero* reference plane (as if the inner and outer conductor planes were intended to be flush). Gage readings can be directly compared with the *observed* values listed in Table 4-1.

Importance of Pin Depth

The pin depth value of each calibration device in this kit is not specified, but is an important mechanical parameter. The electrical performance of the device depends, to some extent, on its pin depth. The electrical specifications for each device in this kit take into account the effect of pin depth on the device's performance. Table 4-1 lists the typical pin depths and customer measurement uncertainties, and provides observed pin depth limits for the devices in the kit. If the pin depth of a device does not measure within the *observed* pin depth limits, it may be an indication that the device fails to meet electrical specifications. Refer to Figure 4-1 for an illustration of pin depth in type-N connectors.

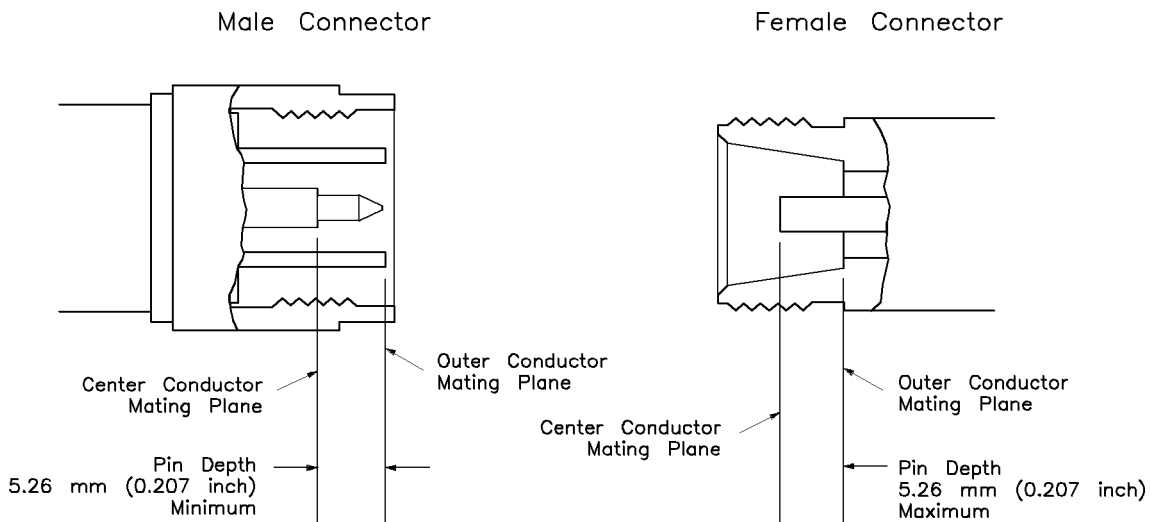

Figure 4-1. Connector Pin Depth

Gaging Connectors

Gage Intent

The gages in this kit are intended for preventive maintenance and troubleshooting purposes only. They are effective in detecting *excessive* center conductor protrusion or recession and connector damage on DUTs, test accessories, and the calibration kit devices. *Do not use gages for precise pin depth measurements.*

Gage Accuracy

The connector gages are only capable of performing coarse measurements. They do not provide the degree of accuracy necessary to precisely measure the pin depth of the kit devices. This is partially due to the repeatability uncertainties that are associated with the measurement. Only the factory, through special gaging processes and electrical testing, can accurately verify the mechanical characteristics of the devices.

With proper technique, however, the gages are useful in detecting gross pin depth errors on device connectors. To achieve maximum accuracy, random errors must be reduced by taking the average of at least three measurements having different gage orientations on the connector. Even then, the resultant average can be in error by as much as ± 0.0001 inch due to systematic (biasing) errors usually resulting from worn gages and gage masters. Table 4-1 assumes new gages and gage masters, therefore, these systematic errors were not included in the uncertainty analysis. As the gages endure more use, the systematic errors could become more significant in the accuracy of the measurement.

The measurement uncertainties (see Table 4-1) are primarily a function of the assembly materials and design, and the unique interaction each device type has with the gage.

The *observed* pin depth limits in Table 4-1 add these uncertainties to the *typical* factory pin depth values to provide practical limits that can be referenced when using the gages. Refer to Chapter 3, “User Information”, for more information on the design of the calibration devices in this kit.

Table 4-1. Pin Depth Limits

Type-N Device	Typical Pin Depth micrometers (10^{-4} inches)	Measurement Uncertainty ¹ micrometers (10^{-4} inches)	Observed Pin Depth Limits micrometers (10^{-4} inches)
Opens	0 to -12.7 (0 to -5.0)	+3.8 to -3.8 (+1.5 to -1.5)	+3.8 to -16.5 (+1.5 to -6.5)
Shorts	0 to -12.7 (0 to -5.0)	+3.8 to -3.8 (+1.5 to -1.5)	+3.8 to -16.5 (+1.5 to -6.5)
Broadband Loads	0 to -15.2 (0 to -6.0)	+3.8 to -3.8 (+1.5 to -1.5)	+3.8 to -19.1 (+1.5 to -7.5)
Adapters (7 mm end)	0 to -50.8 (0 to -20.0)	+3.8 to -3.8 (+1.5 to -1.5)	+3.8 to -54.6 (+1.5 to -21.5)
Adapters (type-N end)	0 to -12.7 (0 to -5.0)	+3.8 to -3.8 (+1.5 to -1.5)	+3.8 to -16.5 (+1.5 to -6.5)

¹ Approximately +2 sigma to -2 sigma of gage uncertainty based on studies done at the factory using the 85054-60049 gage kit (same as kit gages) according to recommended procedures.

Note When measuring pin depth, the measured value (resultant average of three or more measurements) is *not* the true value. Always compare the measured value with the *observed* pin depth limits in Table 4-1 to evaluate the condition of device connectors.

When to Gage Connectors

Gage a connector at the following times:

- Before you use it the first time. It is recommended that you record the initial pin depth measurement of the device to compare with future readings. This serves as a good troubleshooting tool when you suspect damage may have occurred to the device.
- If either visual inspection or electrical performance suggests that the connector interface may be out of typical range (due to wear or damage, for example).
- If a calibration device is used by someone else or on another system or piece of equipment.
- As a matter of routine: initially after every 100 connections, and after that as often as experience suggests.

Reading the Connector Gage

The gage dial is divided up into increments of 0.0001 inch and major divisions of 0.001 inch (see Figure 4-2). For each revolution of the large dial, the smaller dial indicates a change of 0.01 inch. Use the small dial as the indicator of multiples of 0.01 inch. In most connector measuring applications, this value will be zero.

When making a measurement the gage dial indicator will travel in one of two directions. If the center conductor is recessed from the *zero* reference plane, the indicator will travel counterclockwise to determine the amount of *recession*. If the center conductor protrudes, the indicator will move clockwise to measure the amount of *protrusion*.

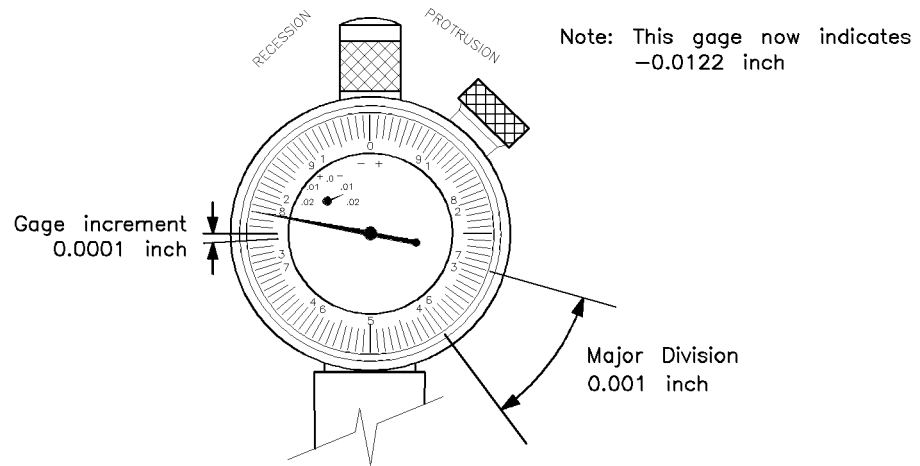

Figure 4-2. Reading the Connector Gage

Adjusting the Connector Gage

Gages are matched with gage masters at the factory. The paired master is then labeled with an offset value to compensate for its inaccuracy with its gage. This label appears on the bottom of all masters that have been paired with gages. When setting the gage with its master, always set the gage to the master offset value shown on the label and not to *zero* unless that is the offset value indicated. Use the following steps to adjust the gage.

Note Hold a connector gage by the gage barrel, below the dial indicator. This gives the best stability, and improves measurement accuracy (cradling the gage in your hand or holding it by the dial applies stress to the gage plunger mechanism through the dial indicator housing).

1. Select the proper gage for your connector. (Refer to Chapter 7, “Replaceable Parts”, for gage part numbers.)
2. Inspect and clean the gage:
 - a. Inspect the connector gage and the gage master carefully, exactly as you inspected the connector itself.
 - b. Clean or replace the gage and the gage master if necessary. Dirt on either the gage or the gage master makes gage measurements inaccurate, and can damage a connector.
3. Adjust the gage (see Figure 4-3):
 - a. While holding the gage by the plunger barrel, use the connecting nut to screw on the gage master just until you meet resistance.
 - b. Use the torque wrench supplied with the kit to tighten the connecting nut of the gage master.
 - c. Loosen the dial lock screw on the gage and rotate the gage dial so that the pointer corresponds to the correction value noted on the gage master (see Figure 4-3). Do not adjust the gage dial to zero, unless the correction value on the gage master is zero.
 - d. Tighten the dial lock screw and remove the gage master.
 - e. Attach and torque the gage master to the gage once again to verify that the setting is repeatable. Remove the gage master.

Note Check gages often to make sure that the adjustment has not changed. Generally, when the pointer on a recently adjusted gage does not line up exactly with the correction value, the gage or gage master needs cleaning. Clean both of these carefully and check the adjustment reading again.

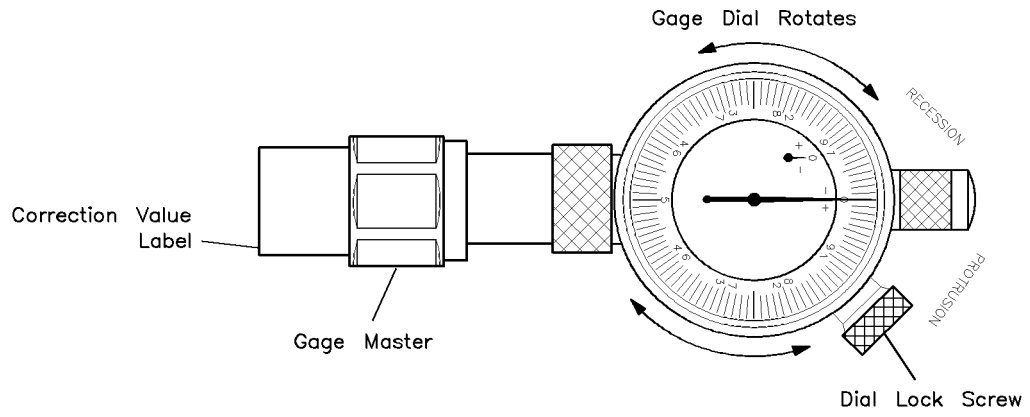

Figure 4-3. Adjusting the Connector Gage

Measuring the Connector

Male Type-N Connectors

1. Refer to Figure 4-4.
2. Adjust the gage as described in “Adjusting the Connector Gage.”
3. While holding the gage by the barrel, screw on the connector of the device being measured. Without turning the gage or the device, connect the nut finger-tight.
4. Torque the connector onto the gage to 135 N-cm (12 in-lb).
5. Gently tap the barrel of the gage with your finger to settle the gage reading.
6. Read the gage indicator dial. If the needle had moved clockwise, the center conductor is protruding and the value is determined by the *black* numbers. If the needle had moved counterclockwise, the center conductor is recessed by an amount determined by the *red* numbers.
7. For maximum accuracy, measure the connector a minimum of three times and take an average of the readings.
8. Compare the average reading with the *observed* pin depth limits in Table 4-1.

Note

When performing pin depth measurements, use different orientations of the gage within the connector. Averaging a minimum of three readings, each taken after a quarter-turn rotation of the gage, reduces measurement variations that result from the gage or the connector face not being exactly perpendicular to the center axis.

- Use screw-on male connector gage.

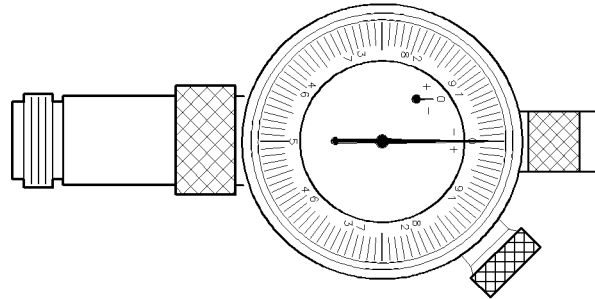

- Connect gage master and adjust gage to correction value called out on gage master label. Tighten dial lock screw after adjustment.

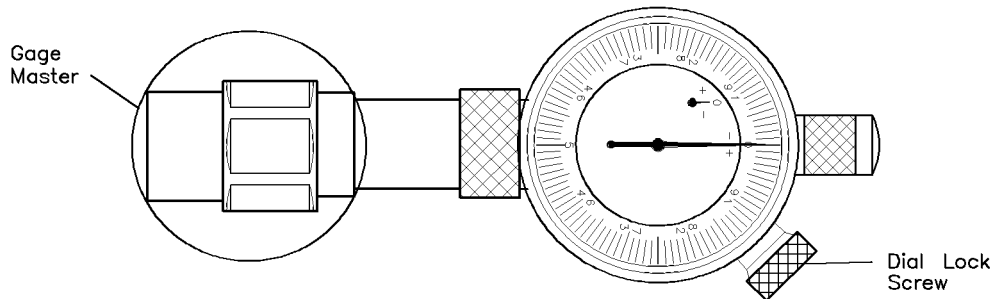

- Screw the device onto the gage. Torque the connecting nut. Gently tap the barrel to settle the gage reading. Read recession or protrusion from the gage.

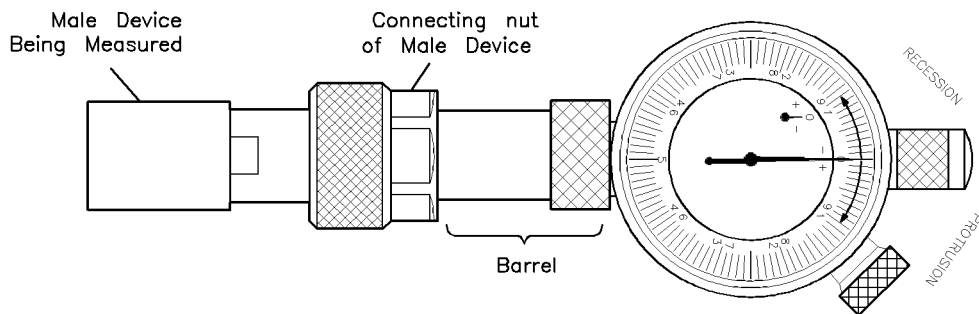

Figure 4-4. Gaging a Type-N Male Connector

Female Type-N Connectors

1. Refer to Figure 4-5.
2. Adjust the gage as described in “Adjusting the Connector Gage.”
3. While holding the gage by the barrel, screw it onto the connector of the device being measured. Without turning the gage or the device, connect the nut finger-tight.
4. Torque the connector onto the gage to 135 N-cm (12 in-lb).
5. Gently tap the barrel of the gage with your finger to settle the gage reading.
6. Read the gage indicator dial. If the needle had moved clockwise, the center conductor is protruding and the value is determined by the *black* numbers. If the needle had moved counterclockwise, the center conductor is recessed by an amount determined by the *red* numbers.
7. For maximum accuracy, measure the connector a minimum of three times and take an average of the readings.
8. Compare the average reading with the *observed* pin depth limits in Table 4-1.

Note

When performing pin depth measurements, use different orientations of the gage within the connector. Averaging a minimum of three readings, each taken after a quarter-turn rotation of the gage, reduces measurement variations that result from the gage or the connector face not being exactly perpendicular to the center axis.

- Use screw-on female connector gage.

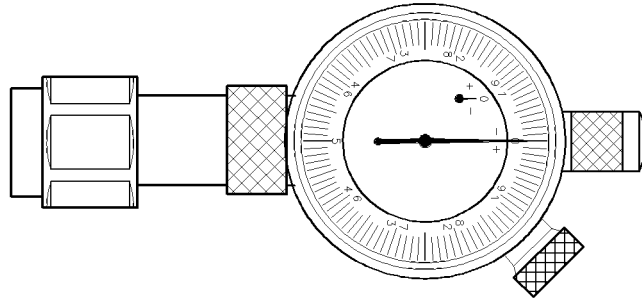

- Connect gage master and adjust gage to correction value called out on gage master label. Tighten dial lock screw after adjustment.

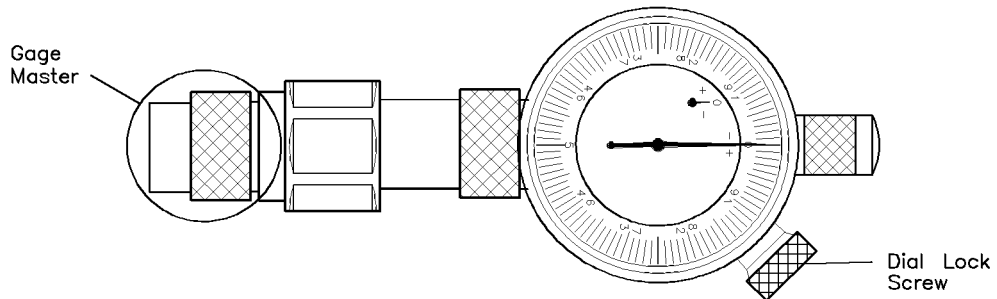

- Screw the device onto the gage. Torque the connecting nut. Gently tap the barrel to settle the gage reading. Read recession or protrusion from the gage.

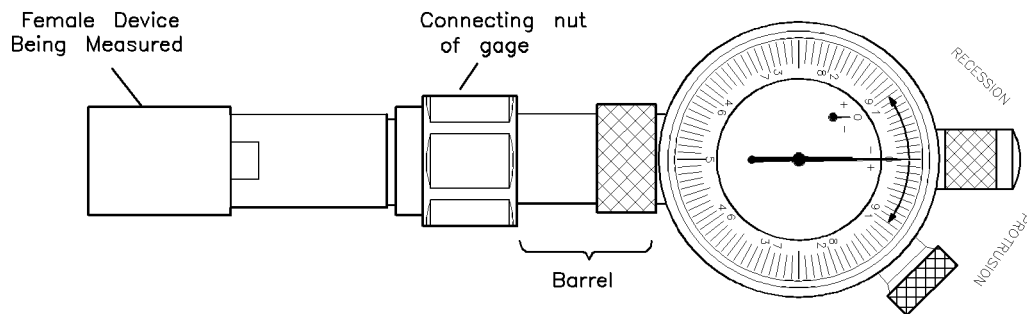

Figure 4-5. Gaging a Type-N Female Connector

Connections

Good connections require a skilled operator. Instrument sensitivity and coaxial connector mechanical tolerances are such that slight errors in operator technique can have a significant effect on measurements and measurement uncertainties. *The most common cause of measurement error is poor connections.*

Follow these recommendations for optimum connection technique:

- Clean and inspect (visually and mechanically) all connectors.
- Align connectors carefully. Look for flat physical contact at all points on the mating plane surfaces
- Make a gentle, preliminary connection.
- When you make a connection, turn *only* the connector nut. Do not rotate a device when you make a connection and do not apply lateral or horizontal (bending) force.
- Use an open-end wrench to keep the device from rotating when making the final connection with the torque wrench (see Figure 4-6).

Connection Procedure

1. Ground yourself and all devices (wear a grounded wrist strap and work on an antistatic mat).
2. Visually inspect the connectors.
3. If necessary, clean the connectors.
4. Use a connector gage to verify that all center conductors are within the *observed* pin depth values in Table 4-1.
5. Carefully align the connectors.

The male connector center pin must slip concentrically into the contact fingers of the female connector.

6. Push the connectors straight together. Do *not* twist or screw them together. As the center conductors mate, there is usually a slight resistance.

CAUTION Do *not* twist one connector into the other (like inserting a light bulb). This happens if you turn the device body rather than the connector nut. Major damage to the center conductor can occur if the device body is twisted.

7. The preliminary connection is tight enough when the mating plane surfaces make uniform, light contact. Do not overtighten this connection.

At this point all you want is a connection in which the outer conductors make gentle contact at all points on both mating surfaces. Very light finger pressure (no more than 2 inch-pounds of torque) is enough.

8. Relieve any side pressure on the connection from long or heavy devices or cables. This assures consistent torque in the following steps.

Using the Torque Wrench

1. Use the torque wrench supplied with the kit to make the final connection. Table 4-2 provides information on the torque wrench required for the connector type found in this kit.

Table 4-2. Torque Wrench Information

Connector Type	Torque Setting	Torque Tolerance
Type-N	135 N-cm (12 in-lb)	8.1 N-cm (± 5 in-lb)

Using the torque wrench guarantees that a connection is not too tight, preventing possible connector damage. It also guarantees that all connections are equally tight each time.

2. Prevent the rotation of anything other than the connector nut that you are going to tighten. This may be possible to do by hand if one of the connectors is fixed (as on a test port). Even then, it may be difficult with small devices. In all situations, the use of an open-end wrench to keep the body of the device from turning is recommended. Position both wrenches within 90 degrees of each other before applying force. Wrenches opposing each other (180 degrees apart) will cause a *lifting action* which can misalign and stress the connections of the devices involved. This is especially true when several devices are connected together (see Figure 4-6).

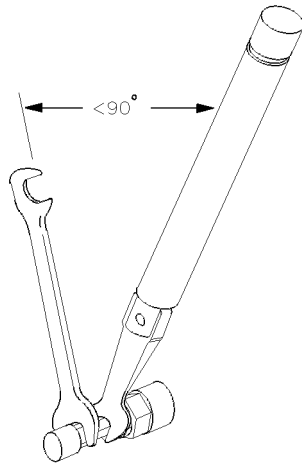

wj67d

Figure 4-6. Correct Wrench Position

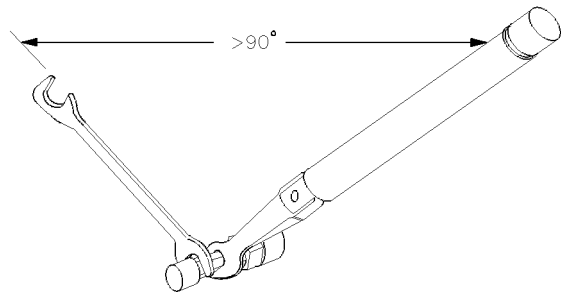

wj613d

Figure 4-7. Incorrect Wrench Position

3. Hold the torque wrench lightly, at the end of the handle only (beyond the groove). (see Figure 4-8).

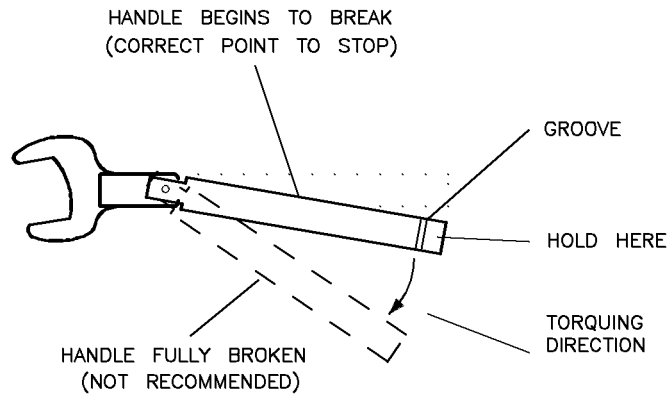

Figure 4-8. Using the Torque Wrench

4. Apply force perpendicular to the wrench handle. This applies torque to the connection *through* the wrench.

Do *not* hold the wrench so tightly that you push the handle straight down along its length rather than pivoting it, otherwise you apply an unlimited amount of torque.

5. Tighten the connection just to the torque wrench “break” point. The wrench handle gives way at its internal pivot point (see Figure 4-8). Do *not* tighten the connection further.

CAUTION You don’t have to “fully break” the handle of the torque wrench to reach the specified torque; doing so can cause the handle to kick back and loosen the connection. Any give *at all* in the handle is sufficient torque.

Do *not* pivot the wrench handle on your thumb or other fingers, otherwise you apply an unknown amount of torque to the connection when the wrench reaches its “break” point.

Do *not* twist the head of the wrench relative to the outer conductor mating plane. If you do, you apply more than the recommended torque.

Disconnection Procedure

Note To avoid lateral (bending) force on the connector mating plane surfaces, always support the devices and connections.

1. Use an open-end wrench to prevent the device body from turning.
 2. Use another wrench to loosen the connector nut.
 3. Complete the disconnection by hand, turning only the connector nut.
-

CAUTION Do *not* twist one connector out of the other (like removing a light bulb). Turn the connector nut, not the device body. Major damage to the center conductor can occur if the device body is twisted.

4. Pull the connectors straight apart without twisting or bending.
-

Handling and Storage

- Store calibration devices in a foam-lined storage case.
- Never store connectors loose in a box, in a desk, or in a bench drawer. This is the most common cause of connector damage during storage.
- Keep connectors clean.
- Do not touch mating plane surfaces. Natural skin oils and microscopic particles of dirt are easily transferred to a connector interface and are very difficult to remove.
- Do not set connectors contact-end down on a hard surface. The plating and the mating plane surfaces can be damaged if the interface comes in contact with any hard surface.
- When you are not using a connector, use plastic end caps over the mating plane surfaces to keep them clean and protected.

Performance Verification

The performance of your calibration kit can only be verified by returning the kit to Hewlett-Packard for recertification. The equipment and calibration standards required to verify the specification limits of the devices inside the kit have been specially manufactured and are not commercially available. Hewlett-Packard recognizes its responsibility to provide you with procedures to reconfirm the published specifications of any product offered. That commitment applies equally to the HP 85054B type-N calibration kit. If it is imperative that the performance test processes for this kit be explained or made available to you, contact the nearest Hewlett-Packard sales and service office listed at the back of this service manual.

To confirm that your calibration kit is performing accurate calibrations use the HP 85055A verifications Kit with the “Specifications & Performance Verification” disk included in this kit.

What Recertification Provides

The following will be provided with a recertified kit:

- New calibration sticker affixed to the case.
- Certificate of Calibration.
- List of NIST (United States National Institute of Standards and Technology) traceable numbers.
- A calibration report for each device in the kit listing measured values, specifications, and uncertainties.

Hewlett-Packard offers both a *Standard* and a *U.S. MIL-STD 45662A* calibration for the recertification of this kit. For more information, contact the nearest Hewlett-Packard office (sales and service offices are listed at the back of this manual).

Recertification of opens and shorts are referenced to the HP 8510 cal coefficients only. The HP 8510 is the most accurate model of the devices (the HP 8720 is not used).

How Often to Recertify

The suggested initial interval for recertification is 12 months or sooner. The actual need for recertification depends on the use of the kit. After reviewing the results of the initial recertification, you may establish a different recertification interval that reflects the usage and wear of the kit.

Note In some cases, the first time a kit is used after being recertified occurs some time after the actual recertification date. The recertification interval should begin on the date the kit is *first used*.

Where to Send a Kit for Recertification

Contact the sales and service office nearest you for information on where to send your kit for recertification (offices are listed in the rear of this manual). When you return the kit, fill out and attach a service tag. (Refer to “Returning a Kit or Device to HP” in Chapter 6, “Troubleshooting.”)

How Hewlett–Packard Verifies the Devices in this Kit

Hewlett–Packard verifies the specifications of these devices as follows:

The residual microwave error terms of the test system are verified with precision airlines and shorts, and low frequency resistance. The resistance is then directly traced back to NIST (United States National Institute of Standards and Technology). The airline and short characteristics are developed from mechanical measurements. The mechanical measurements and material properties are carefully modeled to give very accurate electrical representation. The mechanical measurements are then traced back to NIST through various plug and ring gages and other mechanical measurements.

Each calibration device is electrically tested on this test system to the specifications listed in this manual.

These two steps establish a traceable link to NIST for Hewlett–Packard to the extent allowed by the Institute’s calibration facility. The devices in this kit are traceable to NIST through Hewlett–Packard.

Troubleshooting

If you suspect a bad calibration or if your network analyzer does not pass performance verification, follow the steps in Figure 6-1.

Returning a Kit or Device to HP

If your kit or device requires service, contact the HP office nearest you for information on where to send it (sales and service offices are listed at the back of this manual). When you send the kit or device to Hewlett-Packard, include a service tag (found at the end of this manual) on which you provide the following information:

- Your company name and address.
- A technical contact person within your company, and the person's complete phone number.
- If you are returning a complete kit, include the model number and serial number.
- If you are returning one or more devices, include the part numbers and serial numbers.
- Indicate the type of service required.
- Include any applicable information. If a repair is needed, please describe the problem.

More Information

This manual contains limited information about network analyzer system operation. For complete information, refer to the instrument documentation.

If you need additional information, contact your local Hewlett-Packard representatives. Sales and service offices are listed at the rear of this manual.

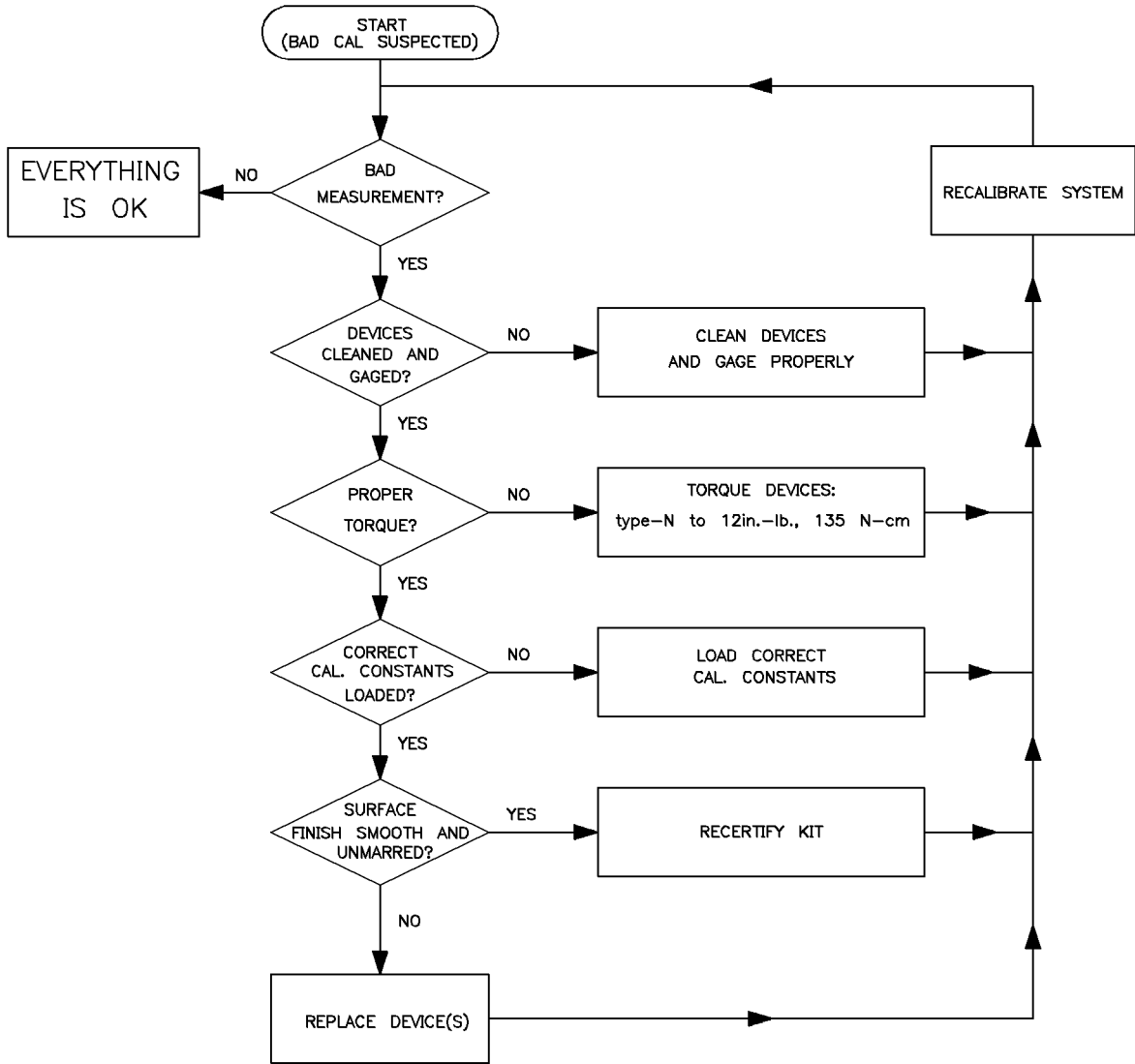

Figure 6-1. Troubleshooting Flowchart

Replaceable Parts

Table 7-1 lists the replacement part numbers for the HP 85054D calibration kit contents. To order a listed part, note the description, HP part number, and the quantity desired. Telephone or send your order to the nearest Hewlett-Packard sales and service office (are listed at the back of this manual).

Table 7-1. Replaceable Parts

Description	Qty Per Kit	HP Replacement Part Number
Calibration Devices		
Type-N Broadband Load (m)	1	85054-60046
Type-N Broadband Load (f)	1	85054-60047
Type-N Offset Short (m)	1	85054-60025
Type-N Offset Short (f)	1	85054-60026
Type-N Offset Open (m)	1	85054-60027
Type-N Offset Open (f)	1	85054-60028
Adapters		
Type-N (m) to Type-N (m)	1	85054-60038
Type-N (f) to Type-N (f)	1	85054-60037
Type-N (f) to 7 mm	2	85054-60031
Type-N (m) to 7 mm	2	85054-60032
Wrenches		
3/4 in., 135 N-cm (12 in-lb) Torque	1	8710-1766
Spanner	1	08513-20014
Miscellaneous Items		
Storage Case Assembly	1	85054-60048
Operating and Service Manual	1	85054-90050
Calibration Constants Tape (option 002)	1	85054-10003
Calibration Constants Disk	1	85054-10006
Specifications & Performance Verification Disk ¹	1	08510-10033
Protective End Cap (f)	6	1401-0225
Protective End Cap (m & 7 mm)	8	1401-0208
Connector Care-Quick Reference Card	1	08510-90360

¹ See the HP 8510C *On-Site Service Manual* for instructions on using this disk.

Table 7-1. Replaceable Parts (continued)

Description	Qty Per Kit	HP Replacement Part Number
Not Included In This Kit		
Type-N Gage Set HP Product Note 5A Open-end wrench 1/2 in. to 9/16 in. Open-end wrench 3/4 in. d Adapter Type-N to 7 mm 50Ω (m) (extendable/retractable sleeve) Adapter Type-N to 7 mm 50Ω (f) (extendable/retractable sleeve) Blank Tape (for data backup) Isopropyl Alcohol (30 ml) Cleaning Swabs (100) Grounding Wrist Strap 5 ft Grounding Cord for Wrist Strap 2 × 4 ft Conductive Table Mat and 15 ft Ground Wire Heel Strap (for conductive floors)		85054-60049 08510-90352 8710-1770 8720-0011 85054-60009 85054-60001 9164-0166 8500-5344 9301-1243 9300-1367 9300-0980 9300-0797 9300-1126

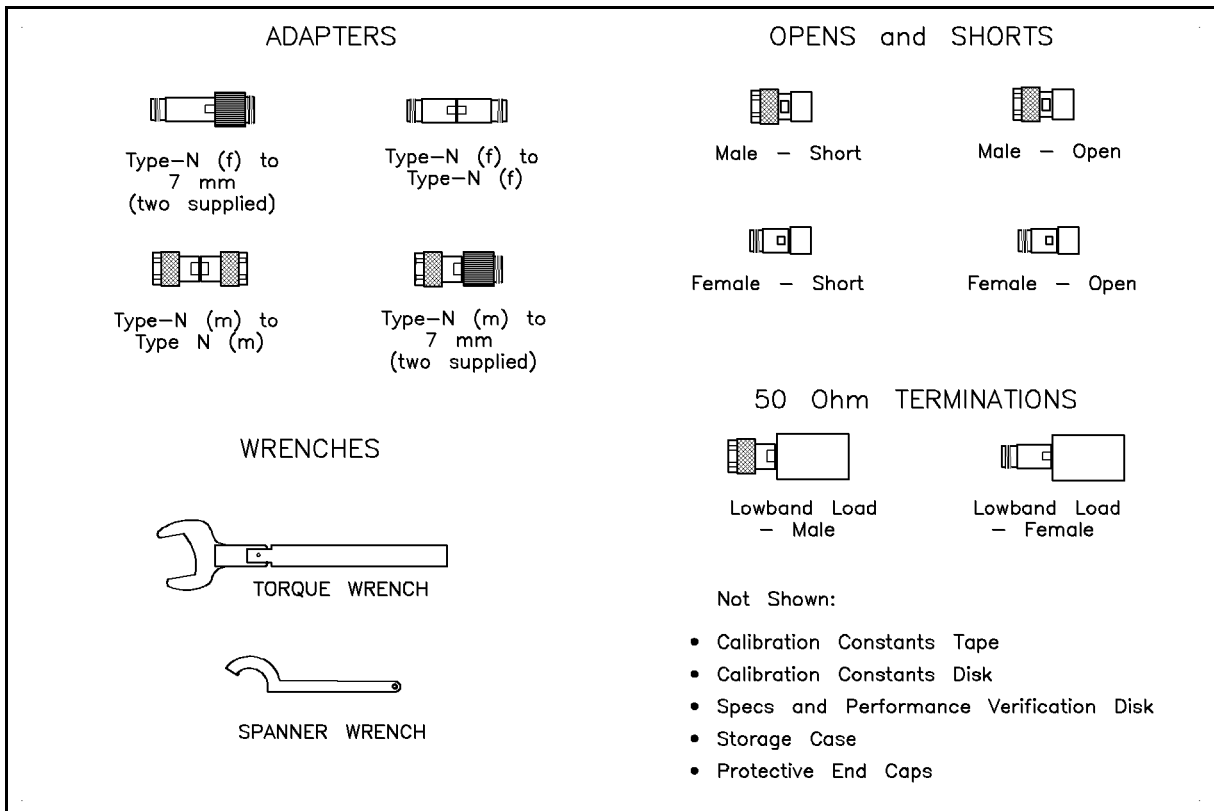

Figure 7-1. Replaceable Parts

Standard Definitions

Electrical Characteristics

Standard Class Assignments

Class assignment organizes calibration standards into a format compatible with the error models used in measurement calibration. A class or group of classes corresponds to the systematic errors to be removed from the measured network analyzer response. Table A-1 and Table A-2 list the classes used by the HP 8510 and HP 8720 series respectively.

Nominal Standard Definitions

Standard definitions provide the constants needed to mathematically model the electrical characteristics (delay, attenuation, and impedance) of each calibration standard. The nominal values of these constants are theoretically derived from the physical dimensions and material of each calibration standard, or from actual measured response. These values are used to determine the measurement uncertainties of the network analyzer. The standard definitions, Table A-4 and Table A-5, list typical calibration kit parameters used by the HP 8510 and HP 8720 series to specify the mathematical model of each device.

Note	The values in the standard class assignments and in the standard definitions tables are valid <i>only</i> over the specified operating temperature range. For information on how to generate alternate characteristics for temperatures outside this range, refer to HP product note 8510-5A, "Specifying Calibration Standards for the HP 8510 Network Analyzer." This product note provides information on modifying calibration constants, parameters, and classes.
-------------	--

Setting System Impedance

Ensure the system impedance (Z_0) is set to the same value as the standards being used. This kit contains only 50 ohm devices. For the HP 8510 and HP 8720 series, do the following:

1. Press **CAL** **MORE** **SET Z0**.
2. Observe the display to determine *current* system impedance.
3. If it is not 50 ohms, press **5** **0** **X1**.

Version Changes

Class assignments and standard definitions may change as more accurate model and calibration methods are developed. The disk (or option 002 tape) shipped with the kit for use with the HP 8510 will contain the most recent version. The default version that comes with the HP 8720 series network analyzer firmware may be outdated.

**Table A-1.
Standard Class Assignments
for the HP 8510**

Calibration Kit Label: TYPE N D.2

Disk File Name: CK_NTYPD2

Tape File Number: * FILE 1

Class	A	B	C	D	E	F	G	Standard Class Label
S ₁₁ A	2	4						Opens
S ₁₁ B	1	3						Shorts
S ₁₁ C	9	10	12					Loads
S ₂₂ A	2	4						Opens
S ₂₂ B	1	3						Shorts
S ₂₂ C	9	10	12					Loads
Forward Transmission	11							Thru
Reverse Transmission	11							Thru
Forward Match	11							Thru
Reverse Match	11							Thru
Forward Isolation ¹	9							Isol'n Std
Reverse Isolation	9							Isol'n Std
Frequency Response	1	3	2	4	11			Response
TRL Thru	14							undefined
TRL Reflect	1							undefined
TRL Line	15							undefined
Adapter	13	14						Adapters
TRL Option								
Cal Z ₀ : ___ System Z ₀ ___ X ___ Line Z ₀								
Set Ref: ___ X ___ Thru ___ ___ Reflect								
Lowband Frequency: ___ 2.0 GHz ___								

¹ Forward isolation standard is also used for isolation part of response and isolation calibration.

Table A-2.
Standard Class Assignments
for the HP 8720 Series

Calibration Kit Label: [N 50Ω]

Class	A	B	C	D	E	F	G	Standard Class Label
S ₁₁ A	2	8						Opens
S ₁₁ B	1	7						Shorts
S ₁₁ C	3	5	6					Loads
S ₂₂ A	2	8						Opens
S ₂₂ B	1	7						Shorts
S ₂₂ C	3	5	6					Loads
Forward Transmission	4							Thru
Reverse Transmission	4							Thru
Forward Match	4							Thru
Reverse Match	4							Thru
Response	1	7	2	8	4			Response
Response & Isolation	1	7	2	8	4			Response
TRL Thru	4							Thru
TRL Reflect	2	8						Opens
TRL Line	3	5	6					Loads
TRL Option								
Cal Z ₀ : ___ System Z ₀ <u>X</u> Line Z ₀								
Set Ref: <u>X</u> Thru ___ Reflect								

**Table A-3.
Standard Class Assignments
Blank Form**

Calibration Kit Label: _____

Disk File Name: _____

Tape File Number: _____

Class	A	B	C	D	E	F	G	Standard Class Label
S ₁₁ A								
S ₁₁ B								
S ₁₁ C								
S ₂₂ A								
S ₂₂ B								
S ₂₂ C								
Forward Transmission								
Reverse Transmission								
Forward Match								
Reverse Match								
Forward Isolation ¹								
Reverse Isolation								
Frequency Response								
TRL Thru								
TRL Reflect								
TRL Line								
Adapter								
TRL Option								
Cal Z ₀ : ____ System Z ₀ ____ Line Z ₀								
Set Ref: ____ Thru ____ Reflect								
Lowband Frequency: _____								

¹ Forward isolation standard is also used for isolation part of response and isolation calibration.

**Table A-4.
Standard Definitions
HP 8510 with Type-N**

System $Z_0^a = 50.0 \Omega$

Calibration Kit Label: TYPE N D.2

Disk File Name: CK_NTPD2

Tape File Number: * FILE 1

STANDARD ^b		C0 $\times 10^{-15}$ F	C1 $\times 10^{-27}$ F/Hz	C2 $\times 10^{-36}$ F/Hz ²	C3 $\times 10^{-45}$ F/Hz ³	FIXED ^c or SLIDING	OFFSET			FREQ ^d (GHz)		COAX or WG	STND LABEL
NO.	TYPE	L0 $\times 10^{-12}$ H	L1 $\times 10^{-24}$ H/Hz	L2 $\times 10^{-33}$ H/Hz ²	L3 $\times 10^{-42}$ H/Hz ³		DELAY ps	Z ₀ Ω	LOSS GΩ/s	MIN	MAX		
1	Short ^e	-0.1315	606.21	-68.405	2.0206		27.990	50	1.3651	0	999	Coax	Short (m) ^f
2	Open ^e	104.13	-1943.4	144.62	2.2258		22.905	50	0.93	0	999	Coax	Open (m) ^f
3	Short ^e	0.7563	459.88	-52.429	1.5846		63.078	50	1.1273	0	999	Coax	Short (f) ^f
4	Open ^e	89.939	2536.8	-264.99	13.4		57.993	50	0.93	0	999	Coax	Open (f) ^f
5													
6													
7													
8													
9	Load					Fixed	0	50	0	0	999	Coax	Broadband
10													
11	Delay/Thru						0	50	0	0	999	Coax	Thru
12													
13	Delay/Thru						134.82	50	2.2	0	999	Coax	(f/f) Adapter
14	Delay/Thru						196.0	50	2.2	0	999	Coax	(m/m) Adapter
15													
16													
17													
18													
19													
20													
21													

^a Ensure system Z_0 of network analyzer is set to 50 ohms.

^b Open, short, load, delay/thru, or arbitrary impedance.

^c Load or arbitrary impedance only.

^d For waveguide, lower frequency is same as F_{CO} .

^e Typical values only. Disk/Tape file values may be different.

^f Standard labels which specify sex, (m) or (f), refer to the sex of the test port connector.

**Table A-5.
Standard Definitions
HP 8720 Series with Type-N**

System $Z_0^a = 50 \Omega$

Calibration Kit Label: [N 50Ω]

STANDARD ^b		C0 $\times 10^{-15}$ F	C1 $\times 10^{-27}$ F/Hz	C2 $\times 10^{-36}$ F/Hz ²	C3 $\times 10^{-45}$ F/Hz ³	FIXED ^c or SLIDING	OFFSET			FREQ ^d (GHz)		COAX or WG	STND LABEL
NO.	TYPE						DELAY s	Z_0 Ω	LOSS Ω /ps	MIN	MAX		
1	Short	0	0	0	0		27.99p	50	800M	0	999	Coax	Short (m)
2	Open	88.31	1667.2	-146.61	9.75		22.905	50	800M	0	999	Coax	Open (m)
3	Load					Fixed	0	50	800M	0	999	Coax	Broadband
4	Delay/Thru						0	50	800M	0	999	Coax	Thru
5	Load					Sliding	0	50	800M	1.999	999	Coax	Sliding
6	Load					Fixed	0	50	800M	0	2.001	Coax	Lowband
7	Short						63.078	50	800M	0	999	Coax	Short (f)
2	Open	88.31	1667.2	-146.61	9.75		57.993	50	800M	0	999	Coax	Open (f)

^a Ensure system Z_0 of network analyzer is set to 50 ohms.

^b Open, short, load, delay/thru, or arbitrary impedance.

^c Load or arbitrary impedance only.

^d For waveguide, lower frequency is same as F_{CO} .

**Table A-6.
Standard Definitions
Blank Form**

System $Z_0^a =$ _____

Calibration Kit Label: _____

Disk File Name: _____

Tape File Number: _____

STANDARD ^b		C0 $\times 10^{-15}$ F	C1 $\times 10^{-27}$ F/Hz	C2 $\times 10^{-36}$ F/Hz ²	C3 $\times 10^{-45}$ F/Hz ³	FIXED ^c or SLIDING	TERM ^d IMPED Ω	OFFSET			FREQ ^e (GHz)		COAX or WG	STND LABEL
NO.	TYPE	L0 $\times 10^{-12}$ H	L1 $\times 10^{-24}$ H/Hz	L2 $\times 10^{-33}$ H/Hz ²	L3 $\times 10^{-42}$ H/Hz ³			DELAY ps	Z ₀ Ω	LOSS Ω/s	MIN	MAX		
1														
2														
3														
4														
5														
6														
7														
8														
9														
10														
11														
12														
13														
14														
15														
16														
17														
18														
19														
20														
21														

^a Ensure system Z_0 of network analyzer is set to this value.

^b Open, short, load, delay/thru, or arbitrary impedance.

^c Load or arbitrary impedance only.

^d Arbitrary impedance only, device terminating impedance.

^e For waveguide, lower frequency is same as F_{C0} .

Hewlett-Packard Sales and Service Offices

IN THE UNITED STATES

California

Hewlett-Packard Co.
1421 South Manhattan Ave.
P.O. Box 4230
Fullerton, CA 92631
(714) 999-6700

Hewlett-Packard Co.
301 E. Evelyn
Mountain View, CA 94039
(415) 694-2000

Colorado

Hewlett-Packard Co.
24 Inverness Place, East
Englewood, CO 80112
(303) 649-5000

Georgia

Hewlett-Packard Co.
2000 South Park Place
P.O. Box 105005
Atlanta, GA 30339
(404) 955-1500

Illinois

Hewlett-Packard Co.
5201 Tollview Drive
Rolling Meadows, IL 60008
(312) 255-9800

New Jersey

Hewlett-Packard Co.
120 W. Century Road
Paramus, NJ 07653
(201) 265-5000

Texas

Hewlett-Packard Co.
930 E. Campbell Rd.
Richardson, TX 75081
(214) 231-6101

IN AUSTRALIA

Hewlett-Packard Australia Ltd.
31-41 Joseph Street
Blackburn, Victoria 3130
895-2895

IN CANADA

Hewlett-Packard (Canada) Ltd.
17500 South Service Road
Trans-Canada Highway
Kirkland, Quebec H9J 2X8
(514) 697-4232

IN FRANCE

Hewlett-Packard France
F-91947 Les Ulis Cedex
Orsay
(6) 907-78-25

IN GERMAN FEDERAL REPUBLIC

Hewlett-Packard GmbH
Vertriebszentrale Frankfurt
Berner Strasse 117
Postfach 560 140
D-6000 Frankfurt 56
(0611) 50-04-1

IN GREAT BRITAIN

Hewlett-Packard Ltd.
King Street Lane
Winnesh, Wokingham
Berkshire RG11 5AR
0734 784774

IN OTHER EUROPEAN COUNTRIES

Hewlett-Packard (Schweiz) AG
Allmend 2
CH-8967 Widen (Zurich)
(0041) 57 31 21 11

IN JAPAN

Yokogawa-Hewlett-Packard Ltd.
29-21 Takaido-Higashi, 3 Chome
Suginami-ku Tokyo 168
(03) 331-6111

IN PEOPLE'S REPUBLIC OF CHINA

China Hewlett-Packard, Ltd.
P.O. Box 9610, Beijing
4th Floor, 2nd Watch Factory
Main Bldg.
Shuang Yu Shu, Bei San Huan Rd.
Beijing, PRC
256-6888

IN SINGAPORE

Hewlett-Packard Singapore
Pte. Ltd.
1150 Depot Road
Singapore 0410
273 7388
Telex HPSGSO RS34209
Fax (65) 2788990

IN TAIWAN

Hewlett-Packard Taiwan
8th Floor, Hewlett-Packard
Building
337 Fu Hsing North Road
Taipei
(02) 712-0404

IN ALL OTHER LOCATIONS

Hewlett-Packard Inter-Americas
3495 Deer Creek Rd.
Palo Alto, California 94304

Index

8

- 8510
 - use with, 3-2
- 8719
 - use with, 3-6
- 8720
 - use with, 3-6
- 8722
 - use with, 3-6

A

- adapters, 3-1
 - traceability of, 1-3
- avoiding problems, 1-5

C

- calibration
 - certificate of, 5-1
 - temperature, 2-1
- calibration constants
 - changing, 3-5
 - duplicating the disk, 3-3
 - examining, 3-4
 - loading, 3-2
 - version changes, A-1
- calibration kit history, 1-3
- calibration kit overview, 1-1
- calibration report, 5-1
- calibrations
 - on an HP 8510, 3-3
 - on an HP 8719, 3-6
 - on an HP 8720, 3-6
 - on an HP 8722, 3-6
 - performing, 3-3
- center conductor protrusion, 2-2
- Certificate of Calibration, 5-1
- cleaning connectors, 4-2
- connections, 4-1, **4-14**
- connectors
 - care of, 1-1
 - cleaning, 4-2
 - gaging, 4-4–13
 - metrology-grade, 1-4
 - precision slotless, 1-4, 4-2
 - visual inspection, 4-1–2

- connector sex, 1-5
- connector wear, 4-2

D

- data
 - disk, 3-2
 - recertification, 5-1
 - tape, 3-2
- definitions
 - standard, A-1
- device
 - connecting, 4-14
 - disconnecting, 4-17
 - handling, 4-17
 - storage, 4-17
 - temperature, 2-1
 - visual inspection, 4-1–2
- device maintenance, 1-5
- devices, 3-1
 - lowband loads, 3-1
 - opens, 3-1
 - shorts, 3-1
- disconnections, 4-17
- disk, 3-2
 - making a backup, 3-3
- documentation
 - kit serial prefixes that apply, 1-2
 - replacement, 7-1

E

- electrical specifications, 2-3
- electrostatic discharge, 4-1
- equipment required, 1-2
- ESD, 4-1
 - protection, 4-1

G

- gage
 - accuracy, 4-4
 - adjusting of, 4-8
 - intent, 4-4
 - measurement uncertainties, 4-4
 - reading of, 4-6
 - use, 4-8
- gage master
 - correction value, 4-8

gaging, 4-1, **4-4**, 4-4-13
for troubleshooting, 4-6
type-N female connectors, 4-12
type-N male connectors, 4-10
when to, 4-6

H

handling, 4-17
history
of calibration kit, 1-3

I

incoming inspection, 1-4
information
where to find more, 6-1
inspection
damage, 4-1
defects, 4-1
incoming, 1-4
magnification, 4-1
mating plane, 4-2
microscope, 4-1
slotless connectors, 4-2
visual, 4-1-2

K

kit overview, 1-1

L

loading calibration constants, 3-2

M

magnification, 4-1
maintenance of devices, 1-5
mechanical characteristics, 2-2
mechanical parameters
pin depth, 4-3
mechanical tolerance, 2-2
metrology-grade connectors, 1-4
microscope, 4-1

N

network analyzers
compatible, 1-1
NIST, 5-2
nominal standard definitions, A-1

O

ordering parts, 7-1
overview, of kit, 1-1

P

part numbers, 7-1
parts, replacing, 7-1
performance verification, 5-1
pin depth, 2-2, **4-3**
description of, 4-3
importance of, 4-3
protruding, 4-3
recessed, 4-3
precision connectors, 1-4
prefix, serial, 1-2
preventive maintenance, 1-5
protrusion, 4-3
center conductor, 2-2
PSC, 1-4

R

recertification, 5-1
how it's done, 5-2
interval, 5-2
what's included, 5-1
where it's done, 5-2
recession, 4-3
replaceable parts, 7-1
connector care supplies, 7-1
documentation, 7-1
required equipment, 1-2
requirements
environmental, 2-1
residual errors, 2-3
return to HP, 6-1

S

serial number, 1-2
device, 1-3
prefix, i
those documented in manual, 1-2
U.S. MIL-STD 45662A, 1-3
serial prefixes
history of, 1-3
sex, connector, 1-5
slotless connectors, 1-4, 4-2
specifications, 2-1
electrical, 2-3
environmental, 2-1
mechanical, 2-2
temperature, 2-1
verifying, 5-1
Specifications and Performance Verification
software, 2-3
standard class assignments, A-1, A-2-4
standard definitions, A-1, A-5-7
static discharge, 4-1
storage, 4-17

system impedance
 determining, A-1
 setting, A-1

T

tape, 3-2
temperature
 calibration, 2-1
 device, 2-1
 error-corrected temperature range, 2-1
 measurement, 2-1
 operating temperature range, 2-1
 verification and measurement, 2-1
test data, 5-1
torque wrench, 4-15
traceability, 5-1, 5-2
troubleshooting, 6-1
type-N

 connecting, 4-14

U

user information, 3-1
U.S. MIL-STD 45662A, 5-1
 device serial numbers, 1-3

V

verification
 temperature, 2-1
visual inspection, 4-1-2

W

warranty, iii

Z

Z_0
 of system, A-1

